

















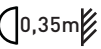
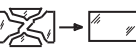

	S	M	L
	 max. 1500 85 x 185 x 350	 max. 1500 130 x 185 x 350	 max. 1500 170 x 185 x 350
kg	0,8	1,2	1,6
	max. 2 x 60 W G9 	max. 2 x 120 W R7s 	max. 2 x 160 W R7s 
	  	    	    

SML SUSPENSION HALOGEN

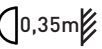
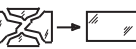

serien
.lighting

serien Raumleuchten GmbH Hainhäuser Str. 3-7 D-63110 Rodgau

Design Jean-Marc da Costa

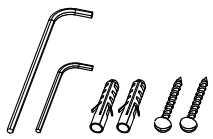

- (D) Vor Montage der Leuchte Sicherung ausschalten!
- (GB) Disconnect fuse prior to installation!
- (F) Pour la pose de luminaire, couper le courant!
- (I) Assicursarsi che la lampada si spenta prima del montaggio!

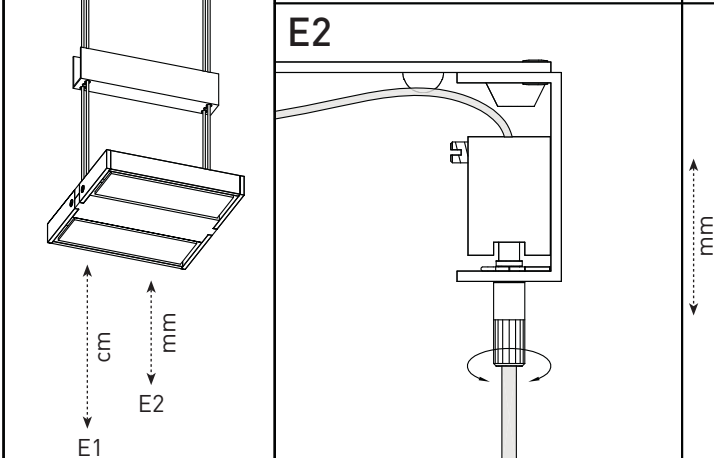
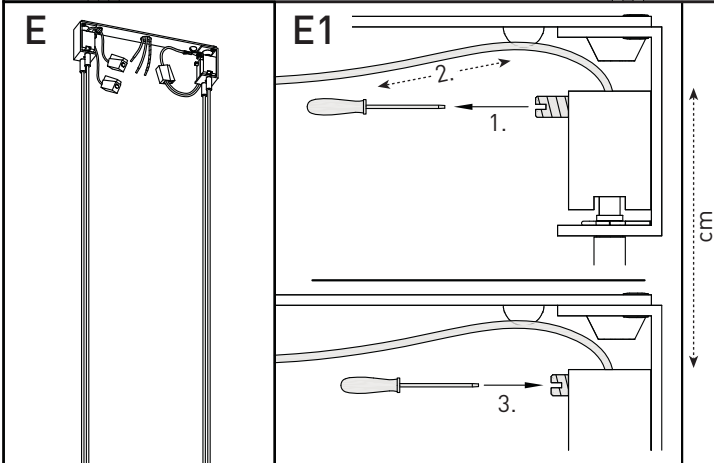
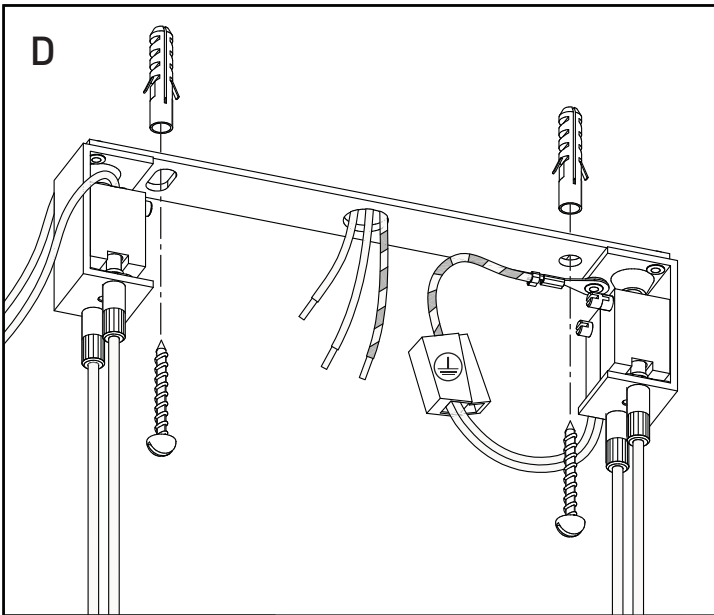
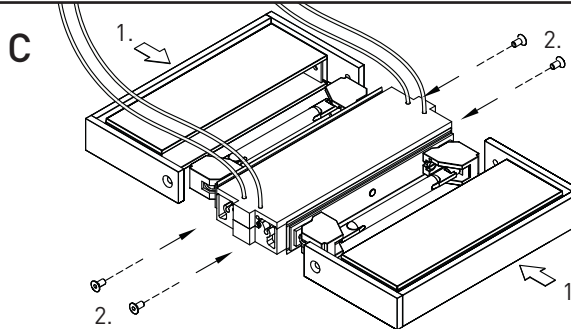
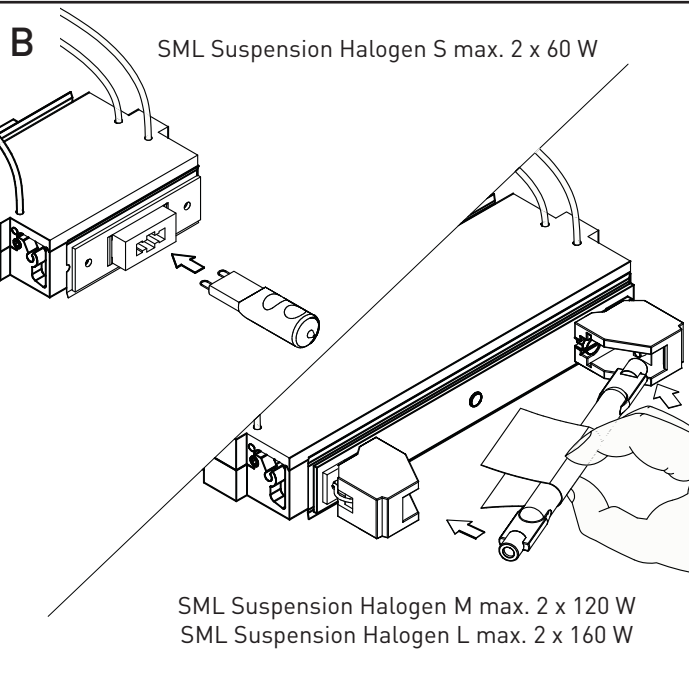
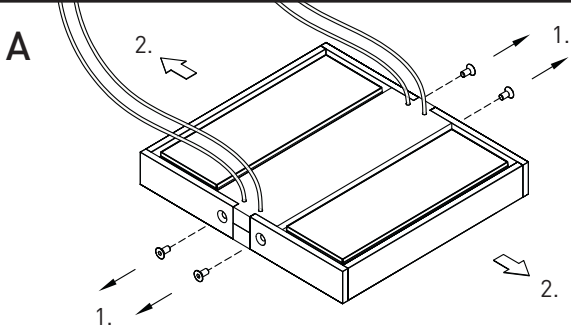

- (D) Die zwei transparenten Erdungsleitungen sind durch einen grün/gelben Faden gekennzeichnet.
- (GB) The two transparent ground wires are marked with a green/yellow thread.
- (F) Les deux lignes transparentes de mise à terre sont marquées d'un fil jaune/vert.
- (I) Le due messe a terra trasparenti sono contrassegnate da un filo verde-giallo.

